

Low noise 150mA LDO regulator

Features:

- Low Power Consumption: 25uA (Typ.)
- Low output noise (27uVRMS)
- Standby Mode: 0.1uA
- Low dropout Voltage: 0.2V@100mA (Typ.)
- High Ripple Rejection: 65dB@1kHz (Typ.)
- Low Temperature Coefficient: $\pm 100\text{ppm}/^\circ\text{C}$
- Excellent Line regulation: 0.05%/V
- Build-in chip enable circuit
- Output Voltage Range: 1.2V~5.0V (customized on command every 0.1V step)
- Highly Accurate: $\pm 2\%$ ($\pm 1\%$ customized)
- Output Current Limit

Applications:

- Power source for cellular phones and various kind of PCSs
- Battery Powered equipment
- Power Management of MP3, PDA, DSC, Mouse, PS2 Games
- Reference Voltage Source
- Regulation after Switching Power

General Description:

BL8555 series is a group of positive voltage output, low power consumption, low dropout voltage regulator.

BL8555 can provide output value in the range of 1.2V~5.0V every 0.1V step. It also can be customized on command.

BL8555 includes high accuracy voltage reference, error amplifier, current limit circuit and output driver module.

BL8555 has excellent load and line transient response and good temperature characteristics, which can assure the stability of chip and power system. And it uses trimming technique to guarantee output voltage accuracy within $\pm 2\%$.

BL8555 is available in SOT-23-5, SC-70-5 packages which is lead free. It also can available in these packages with lead.

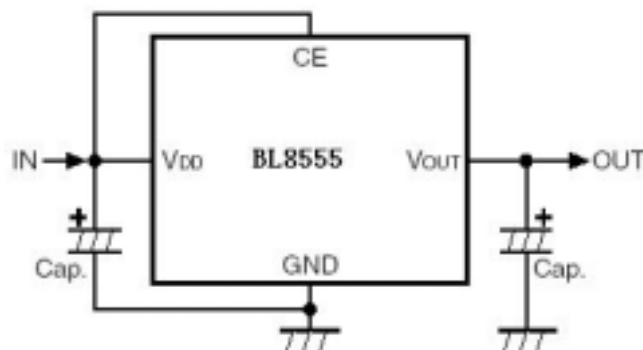

BL8555 Typical Application Circuit

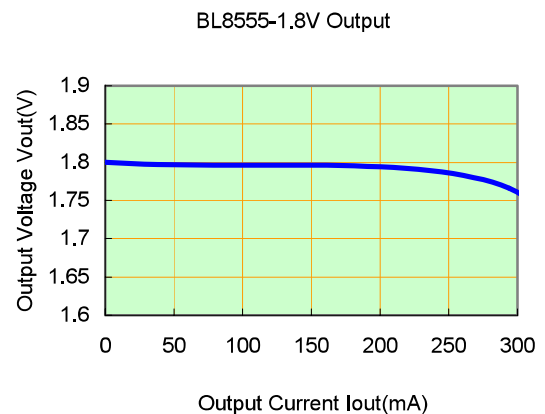

BL8555 Typical Performance Characteristics:

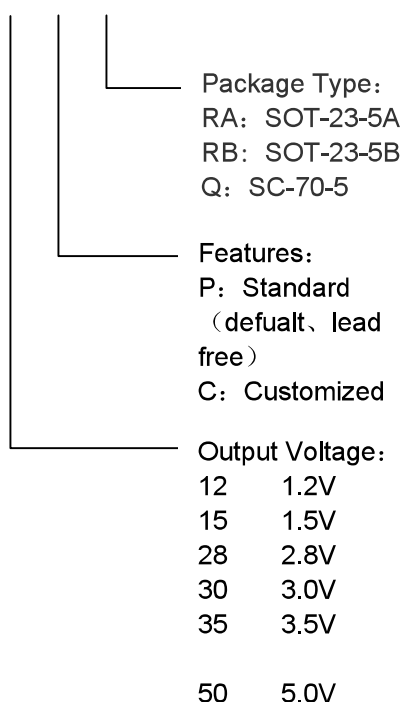

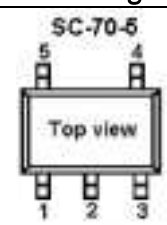
Selection Guide:
BL8555-XX X X

Pin Assignment:

Product Classification	Assembly type & Pin Configuration
BL8555-□□PQ	
BL8555-□□PRA BL8555-□□PRB	

Pin Description:

Pin Number			Symbol	Function
SC-70-5	SOT-23-5A	SOT-23-5B		
5	5	1	VOUT	Output pin
1	1	3	VDD	Input Pin
2	2	2	GND	Ground Pin
3	3	4	CE	Chip Enable Pin
4	4	5	NC	No Connection

Product Classification:

Output Voltage	Package Type	Product Name	Package Type	Product Name	Package Type	Product Name
1.2V	SOT-23-5A	BL8555-12PRA	SOT-23-5B	BL8555-12PRB	SC-70-5	BL8555-12PQ
1.5V	SOT-23-5A	BL8555-15PRA	SOT-23-5B	BL8555-15PRB	SC-70-5	BL8555-15PQ
1.8V	SOT-23-5A	BL8555-18PRA	SOT-23-5B	BL8555-18PRB	SC-70-5	BL8555-18PQ
2.1V	SOT-23-5A	BL8555-21PRA	SOT-23-5B	BL8555-21PRB	SC-70-5	BL8555-21PQ
2.5V	SOT-23-5A	BL8555-25PRA	SOT-23-5B	BL8555-25PRB	SC-70-5	BL8555-25PQ
2.8V	SOT-23-5A	BL8555-28PRA	SOT-23-5B	BL8555-28PRB	SC-70-5	BL8555-28PQ
3.0V	SOT-23-5A	BL8555-30PRA	SOT-23-5B	BL8555-30PRB	SC-70-5	BL8555-30PQ
3.2V	SOT-23-5A	BL8555-32PRA	SOT-23-5B	BL8555-32PRB	SC-70-5	BL8555-32PQ
3.3V	SOT-23-5A	BL8555-33PRA	SOT-23-5B	BL8555-33PRB	SC-70-5	BL8555-33PQ
3.5V	SOT-23-5A	BL8555-35PRA	SOT-23-5B	BL8555-35PRB	SC-70-5	BL8555-35PQ
⋮	⋮	⋮	⋮	⋮	⋮	⋮
5.0V	SOT-23-5A	BL8555-50PRA	SOT-23-5B	BL8555-50PRB	SC-70-5	BL8555-50PQ

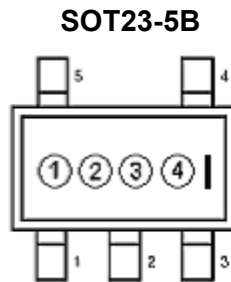
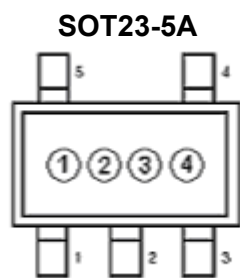
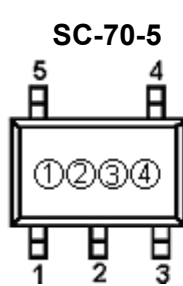
Product Marking information:

- ① : Output current & EN availability
- ② : Output voltage
- ③ : Year of manufacturing
- ④ : Week of manufacturing

①

Code	Iout	EN	代码	Iout	EN
A	50mA	No	A	50mA	Yes
B	100mA	No	B	100mA	Yes
C	150mA	No	C	150mA	Yes
D	200mA	No	D	200mA	Yes
E	250mA	No	E	250mA	Yes
F	300mA	No	F	300mA	Yes
G	350mA	No	G	350mA	Yes
H	400mA	No	H	400mA	Yes
I	450mA	No	I	450mA	Yes
J	500mA	No	J	500mA	Yes

For example:

BL8555 with output current 150mA, SC-82 or SOT-23-5 package with an EN pin, its position ① is C

- ③ The year of manufacturing, "5" stands for year 2005, "6" stands for year 2006, and "8" for year 2010.

②

Code	Vout	Code	Vout	Code	Vout
2	1.2V	7	2.7V	12	4.2V
3	1.3V	8	2.8V	13	4.3V
4	1.4V	9	2.9V	14	4.4V
5	1.5V	0	3.0V	15	4.5V
6	1.6V	1	3.1V	16	4.6V
7	1.7V	2	3.2V	17	4.7V
8	1.8V	3	3.3V	18	4.8V
9	1.9V	4	3.4V	19	4.8V
0	2.0V	5	3.5V	20	5.0V
1	2.1V	6	3.6V		
2	2.12V	7	3.7V		
3	2.3V	8	3.8V		
4	2.4V	9	3.9V		
5	2.5V	0	4.0V		
6	2.6V	1	4.1V		

④

Code	Week of Mfg	Code	Week of Mfg	Code	Week of Mfg	Code	Week of Mfg	Code	Week of Mfg
A	1	L	12	W	23	R	34	S	45
B	2	M	13	X	24	T	35	V	46
C	3	N	14	Y	25	J	36	U	47
D	4	O	15	Z	26	R	37	V	48
E	5	P	16	A	27	L	38	W	49
F	6	Q	17	B	28	M	39	X	50
G	7	R	18	C	29	R	40	Y	51
H	8	S	19	D	30	S	41	Z	52
I	9	T	20	E	31	F	42		
J	10	U	21	F	32	S	43		
K	11	V	22	G	33	R	44		

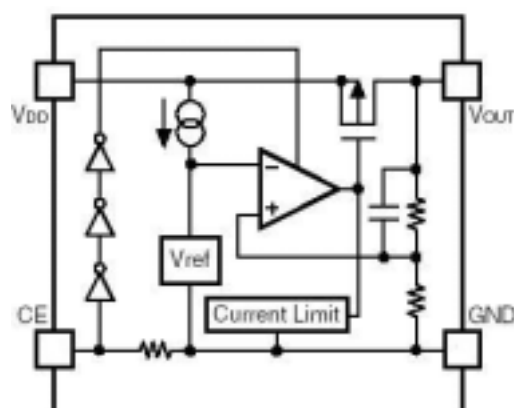
Block Diagram:

Absolute Maximum Ratings:

Max input voltage	-----	10V
Junction Temperature (T _J)	-----	125°C
Output Current	-----	200mA
Power Dissipation		
SOT-23-5	-----	200mW
SC-70-5	-----	200mW
Storage Temperature(T _s)	-----	-45°C~150°C
Lead Temperature and Time	-----	260°C, 10S

Recommended Work Conditions:

Item	Min	Recommended	Max	unit
Input Voltage Range			8	V
Ambient Temperature	-40		85	°C

Electrical Characteristics:

(Test Conditions: C_{in}=1uF, C_{out}=2.2uF, T_A=25°C, unless otherwise specified.)

BL8555, for arbitrary output voltage

Symbol	Parameter	Conditions	Min	Typ	Max	Units
V _{in}	Input Voltage		1.8		8	V
V _{out}	Output Voltage	V _{in} =Set V _{out} +1V 1mA≤I _{out} ≤30mA	V _{out} x0.98		V _{out} X1.02	V
I _{out} (Max.)	Maximun Output Current	V _{in} -V _{out} =1V	150			mA
Dropout Voltage	Input-Output Voltage Differentia	Refer to the ELECTRICAL CHARACTERISTICS by OUTPUT VOLTAGE				
$\frac{\Delta V_{out}}{\Delta V_{in} \cdot V_{out}}$	Line Regulation	I _{out} =40mA 1.6V≤V _{in} ≤8V		0.05	0.2	%/V
$\Delta V_{out} / \Delta I_{out}$	Load Regulation	V _{in} =Set V _{out} +1V 1mA≤I _{out} ≤80mA		12	40	mV
I _{ss}	Supply Current	V _{in} =Set V _{out} +1V		25	50	uA
I _{standby}	Supply Current (S _{randby})	V _{in} =Set V _{out} +1V V _{ce} =Gnd		0.1	1.0	uA
$\frac{\Delta V_{out}}{\Delta T \cdot V_{out}}$	Output Voltage Temperature Coefficiency	I _{out} =30mA		±100		ppm/°C
PSRR	Ripple Rejection	F=1kHz, Ripple=0.5Vp-p V _{in} =Set V _{out} +1V		65		dB
I _{lim}	Short Current Limit	V _{out} =0V		20		mA
R _{pd}	CE Pull down Resistance		2.0	5.0	10.0	MΩ
V _{ceh}	CE Input Voltage "H"		1.5		V _{in}	V
V _{cel}	CE Input Voltage "L"		0		0.25	V
f _{en}	Output Noise	BW=10Hz~100kHz		27		uVrms

Electrical Characteristics by Output Voltage

Output Voltage Vout (V)	Dropout Voltage, V _{DIF} (V)		
	Condition	Typ.	Max.
Vout = 1.5V	Iout = 120mA	0.38	0.70
Vout = 1.6V		0.36	0.65
Vout = 1.7V		0.34	0.60
1.8 ≤ Vout ≤ 2.0		0.32	0.55
2.1 ≤ Vout ≤ 2.7		0.28	0.50
2.8 ≤ Vout ≤ 4.0		0.22	0.35

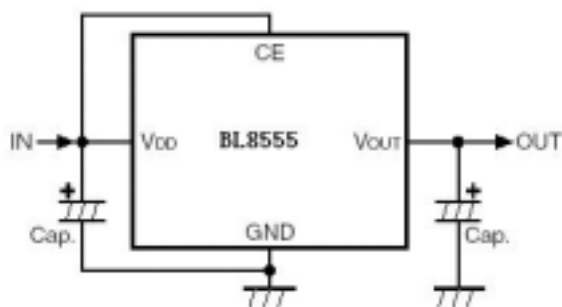
Typical Application Circuit:

Application hints:

NOTE1: Input capacitor (C_{in}=1uF) is recommended in all application circuit.

NOTE2: Output capacitor (C_{out}=1uF/2.2uF) is recommended in all application to assure the stability of circuit.

Explanation:

BL8555 series is a group of positive voltage output, low noise, low power consumption, low dropout voltage regulator.

BL8555 can provide output value in the range of 1.2V~5.0V every 0.1V step. It also can be customized on command.

BL8555 includes high accuracy voltage reference, error amplifier, current limit circuit and output driver module.

BL8555 has excellent load and line transient response and good temperature characteristics, which can assure the stability of chip and power system. And it uses trimming technique to guarantee output voltage accuracy within ±2%.

Typical Performance Characteristics:

1) Output Voltage vs. Output Current (with output short protection)

BL8555-1.8V

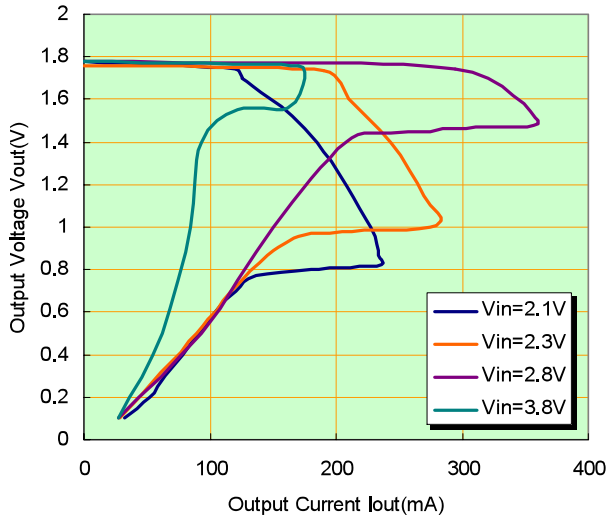

2) Output Voltage vs. Input Voltage

BL8555-1.8V

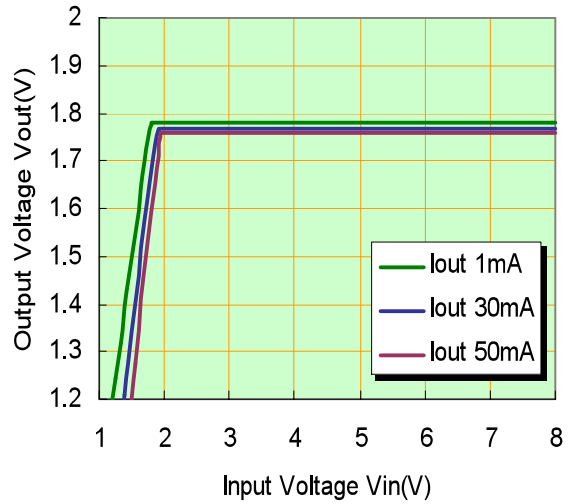

3) Dropout Voltage vs. Output Current

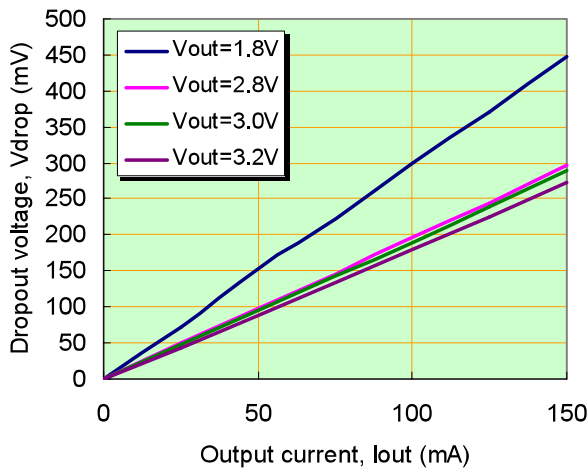

4) Supply Current vs. Input Voltage

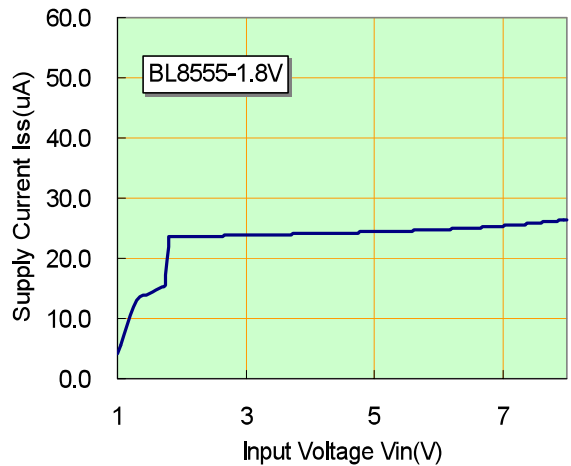

5) Ripple rejection vs. Frequency

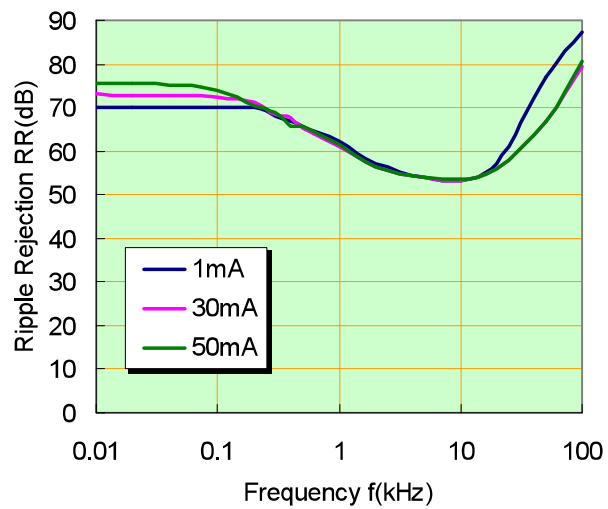

6) Line transient response

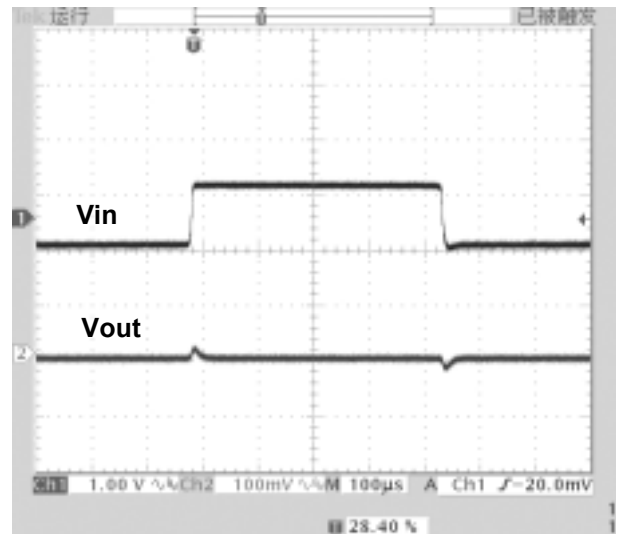

7) Load transient response

